

HIGHLEAD

GA0688-1

**Flat Bed Extra-Heavy Duty
Compound-Feed Lockstitch Sewing Machine**

**Instruction Manual
Parts Catalog**

**Highlead Canada
www.highleadcanada.com**

SHANGHAI HUIGONG NO.3 SEWING MACHINE FACTORY

CONTENTS

1、Precautions before Starting Operation.....	1
■ Safety precautions	1
■ Precautions before Starting Operation	1
■ Precautions for Operation Conditions	1
2、Specification	1
3、PREPARATION FOR OPERATION	2
■ Cleaning the machine	2
■ Examination	2
■ Lubrication	2
■ Testing	2
4、HOW TO ATTACH A NEEDLE	2
5、WINDING OF BOBBIN THREAD.....	3
6、ADJUSTMENT OF THE BOBBIN WINDER	3
■ In case of uneven winding.....	3
■ Winding amount of thread	3
■ Winding strength	3
7、THREADING	4
8、REMOVING AND INSERTING THE BOBBIN.....	4
■ Removing	4
■ Installation	4
9、ADJUSTING THE THREAD TENSION	4
■ Tension of the upper thread	5
■ Tension of the lower thread.....	5
10、ADJUSTMENT OF PRESSER PRESSURE	5
11、ADJUSTMENT OF WALKING FOOT AND PRESSER FOOT.....	6
12、ADJUSTMENT OF STITCH LENGTH AND FORWARD/BACKWARD SEWING.....	6
13、FEED DOG HEIGHT	6
14、ADJUSTING THE HEIGHT OF THE NEEDLE BAR.....	7

1. PRECAUTIONS BEFORES STARING OPERATION

1) Safety precautions:

(1) When turning the power on, keep your hands and fingers away from the area around/under the needle and the area around the pulley.

(2) Power must be turned off when the machine is not in use, or when the operator leaves the seat.

(3) Power must be turned off when tilting the machine head, installing or removing the "V" belt, adjusting the machine, or when replacing.

(4) Avoid placing fingers, hairs, bars etc., near the pulley, "V" belt, bobbin winder pulley, or motor when the machine is in operation.

(5) Do not insert fingers into the thread take-up cover, under/around the needle, or pulley when the machine is in operation.

(6) If a belt cover, finger guard, eye guard are installed, do not operate the machine without these safety devices.

2) Precautions before starting operation:

(1) If the machine's oil pan has an oil sump, never operate the machine before filling it.

(2) If the machine is lubricated by a drop oiler, never operate the machine before lubricating.

(3) When a new sewing machine is first turned on, verify the rotational direction of the pulley with the power on. (The pulley should rotate counterclockwise when viewed from the pulley)

(4) Verify the voltage and (single or three) phase with those given on the machine nameplate.

3) Precautions for operating conditions:

1) Avoid using the machine at abnormally high temperatures (35°C or higher) or low temperatures (5°C or lower) .

2) Avoid using the machine in dusty conditions.

2. SPECIFICATION

Max. sewing speed (r.p.m)	800 r.p.m	
Needle No.	DY×3 26#	
Needle bar stroke (mm)	56	
Thread take-up lever stroke (mm)	96	
Stitch length (mm)	0-15	
Presser-foot stroke	By hand (mm)	13
	By knee (mm)	20
Shuttie hook	KSP-204N	
Lubrication	Manual	

3. PREPARATION FOR OPERATION

(1) Cleaning the machine

Before leaving the factory, the machine parts are coated with rust-preventive grease, which may be hardened and contaminated by dust during storage and shipment. This grease must be removed with gasoline.

(2) Examination

Though every machine is confirmed by strict inspection and test before leaving the factory, the machine parts may be loose or deformed after long distance transportation with jolt. A thorough examination must be performed after cleaning the machine. Turn the pulley to see if there is running obstruction, parts collision, uneven resistance or abnormal noise. If these exist, adjustment must be made accordingly before run-in operation.

(3) Lubrication (Fig.1)

When a new sewing machine is used for the first time, or sewing machine left out of use for considerably long time is used again, replenish a suitable amount of oil to the portions indicated by arrow in below figure.

CAUTION: Please use white spindle oil.

Always keep the presser lifted before attempting a dry run.

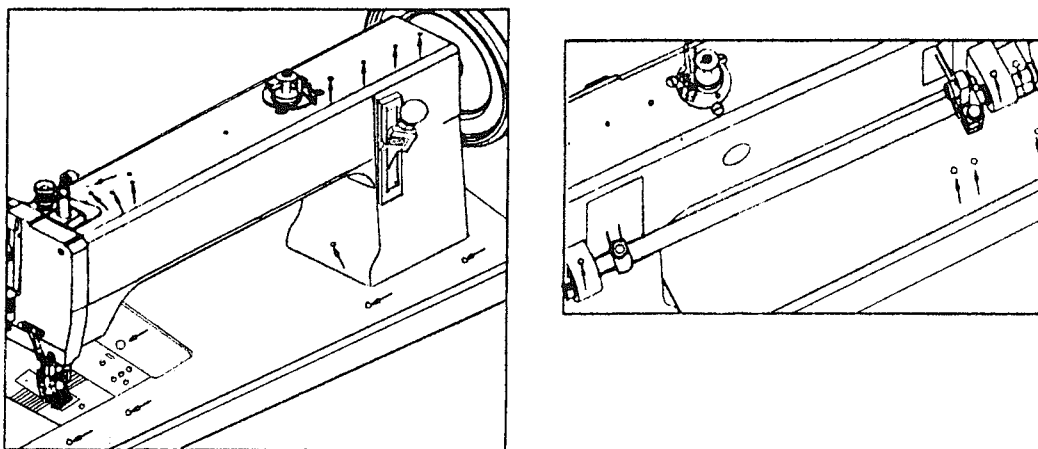

Fig.1

(4) Testing

In order to get the best working situation, run the sewing machine in a low speed for about 1 month after lubricated fully. Then increase the speed to the need one.

4. HOW TO ATTACH A NEEDLE (Fig.2)

CAUTION: Before using the following procedures, be sure to turn the power switch off.

The needle used by this sewing machine is DY×3 26#. During operation, proper needle can be chosen according to the sewing thread. (the sewing thread should be able to pass the pinhole.)

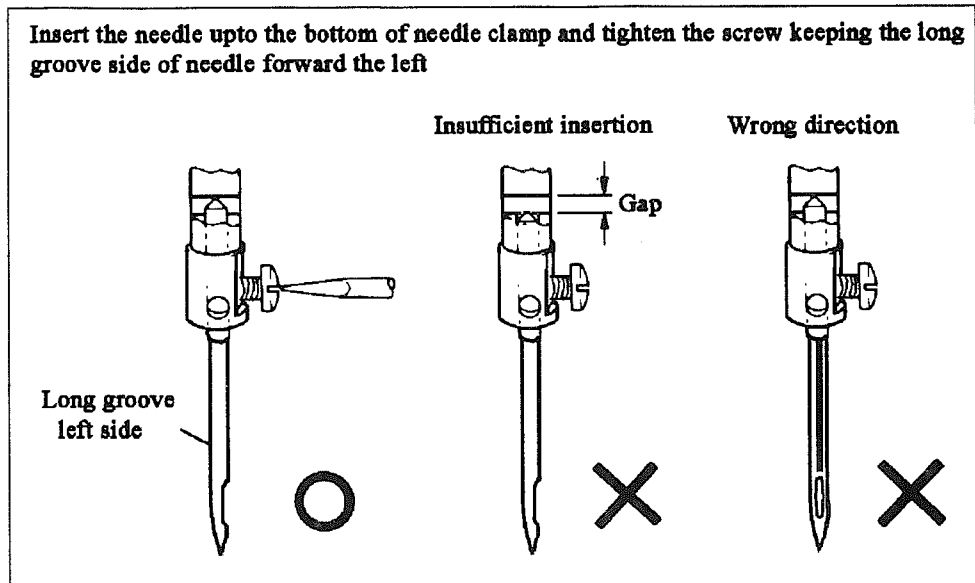

Fig.2

5. WINDING OF BOBBIN THREAD (Fig.3)

- (1) Push the bobbin ③ on the bobbin winder shaft as far as it will go.
- (2) Bring the thread forward toward the bobbin and wind from below in clockwise direction several times around the bobbin.
- (3) Push the lever ⑤ toward other side so that the driving wheel and driven wheel will engage and then start the machine.
- (4) The driven wheel will automatically be free from the driving wheel and stop after the bobbin is filled with thread.

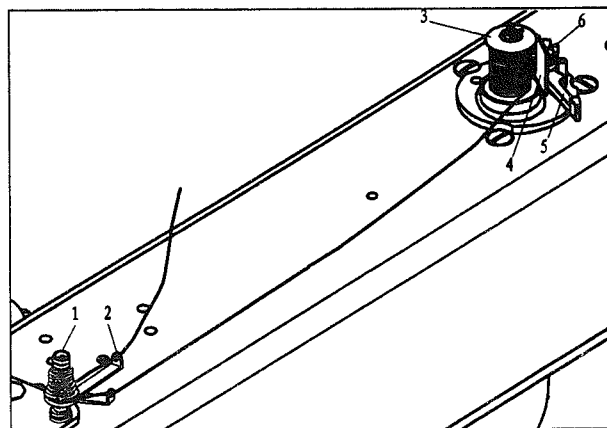

Fig.3

6. ADJUSTMENT OF THE BOBBIN WINDER (Fig.3)

(1) In case of uneven winding

If the thread dose not wind evenly on the bobbin, loosen the nut ① and move the bracket ② to the right or to the left as may be required, then tighten the nut.

(2) Winding amount of thread

Adjusting ⑥ can increase or decrease the amount of thread wound on the bobbin.

(3) Winding strength

Strength of the winding can be adjusted with the nut ①.

7、 THREADING (Fig.4)

Raise the needle bar to its highest position and route the upper thread in the order illustrated below.

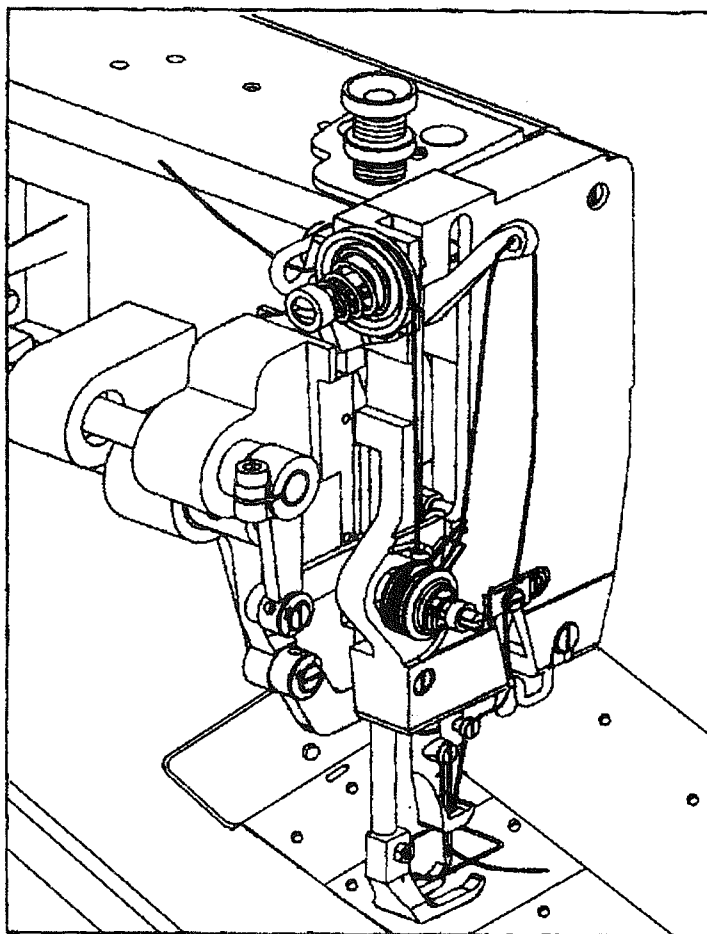

Fig.4

8、 REMOVING AND INSERTING THE BOBBIN

(1) Removing:

Open the shuttle race cap and the bobbin holder, then take out the bobbin.

(2) Installation:

5

Put the bobbin in the rotary hook case, Permit about 5 cm of bobbin thread to hang down freely. Install the bobbin in the bobbin case so that the thread wound direction is clockwise. Then close the rotary hook and the shuttle race cap.

9、 ADJUSTING THE THREAD TENSION (Fig.5)

For ordinary stitching, the tension of the upper and the lower threads should be equal.

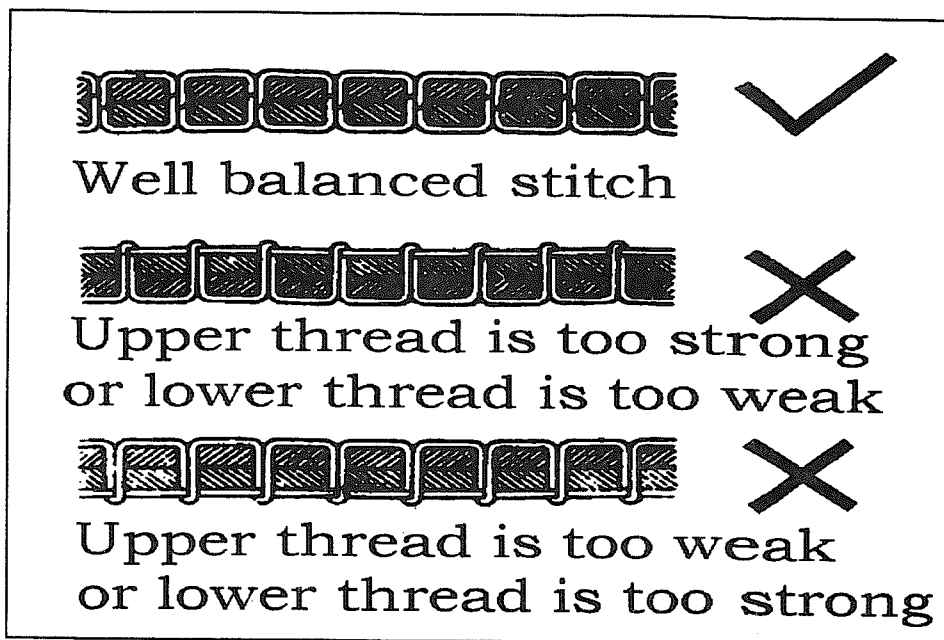

Fig.5

(1) Tension of the Upper thread

Before adjusting the tension of the upper thread, be sure that presser foot is let down. To adjust tension, turn serrated nut on tension device to the right (clockwise) to increase tension and to the left (counter-clockwise) if you desire to decrease the tension.

(2) Tension of the lower thread

The lower thread tension is controlled by the larger screw near the end of the spring at the outside of the bobbin case. Turning this screw to the right (clockwise) will increase the thread tension, while turning it to the left (counter-clockwise) will decrease the tension.

10、 ADJUSTMENT OF PRESSER PRESSURE (Fig.6)

- (1) Pressure should be adjusted according to the material to be sewn.
- (2) Pressure on both the walking foot and the presser foot can be adjusted. (The adjusting screw has been set before shipment.)
- (3) Sewing pressure should be adjusted to the minimum required strength.

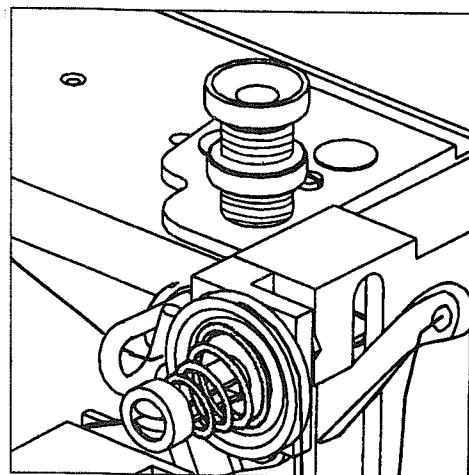

Fig.6

11、 ADJUSTMENT OF WALKING FOOT AND PRESSER FOOT (Fig.7)

- (1) The alternating movement on the walking foot and presser foot can be adjusted by changing the position relations of the parts of the presser foot lifting mechanism.
- (2) Changing the position relation of the connecting link 2 and the crank 3 can complete the adjustment.
- (3) Adjustment should be changed according to the thickness of the material to be sewn..

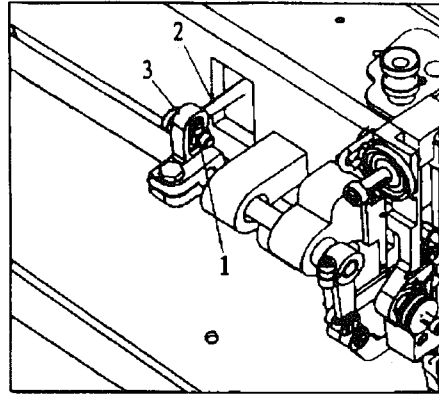

Fig.7

12、 ADJUSTMENT OF STITCH LENGTH AND FORWARD/BACKWARD SEWING (Fig.8)

- (1) Adjusting the stitch length adjusting bolt can change the stitch length.
- (2) Stitch length can be adjusted between 0-15mm.
- (3) Setting the stitch length adjusting bolt above "0" can backstitch.

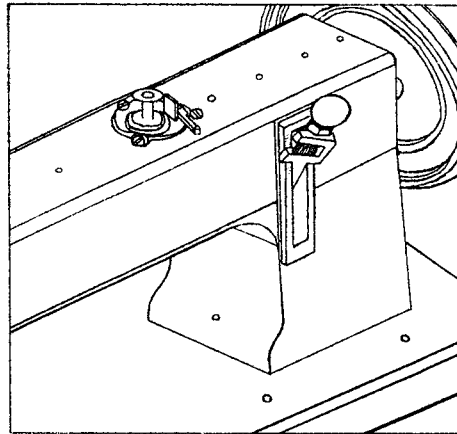

Fig.8

13、 FEED DOG HEIGHT (Fig.9)

The feed dog should be 1.5 mm higher than the vertex of the needle plate. Adjustment of the feed dog height can be done as follows:

- (1) Turn the machine pulley so as to raise the feed dog to its highest point.
- (2) Loosen the screw of the feed dog and adjust the height by raising or lowering it. Then tighten the screw.

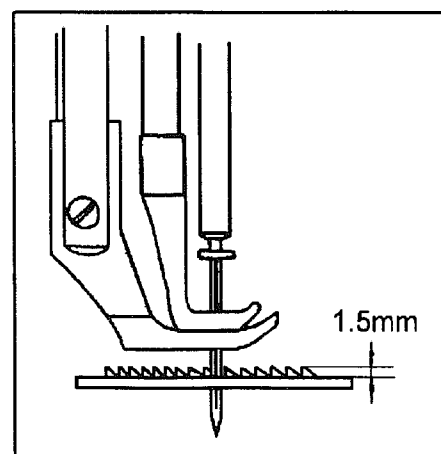

Fig.9

14、 ADJUSTING THE HEIGHT OF THE NEEDLE BAR (Fig.10)

When the needle bar is at its highest point, normally the measurement between the highest point of the needle plate and the needlepoint is 28 mm. When this distance need to be adjusted, the steps is as follows:

- (1) Take down the face plate, adjust the needle bar to its highest position.
- (2) Loosen the screw of needle bar connecting stud screw.
- (3) Adjust the needle bar to the right position.
- (4) Tighten the screw.

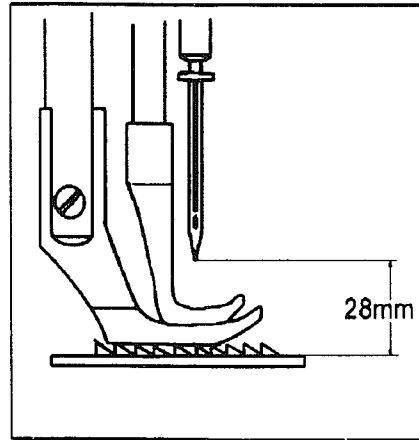
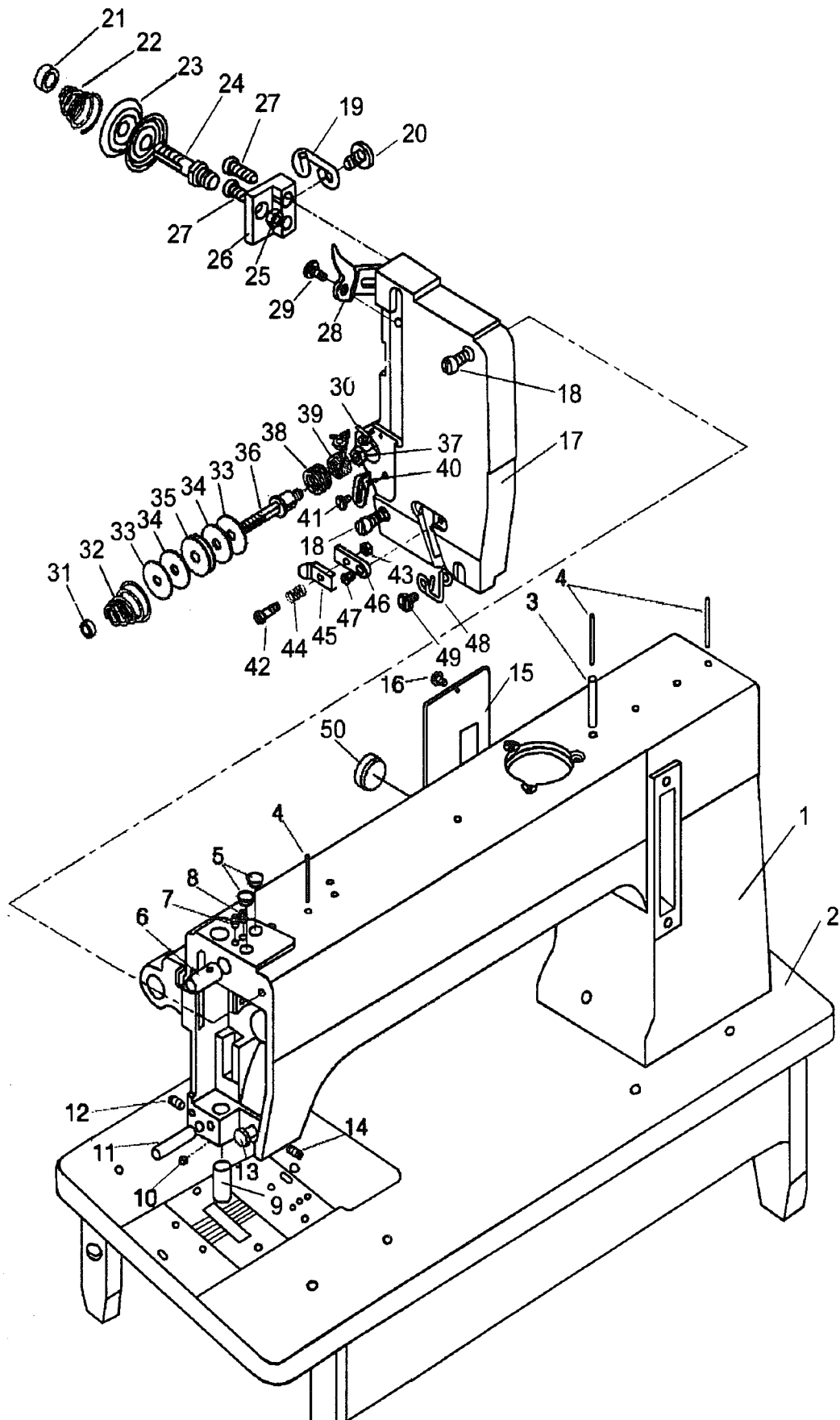

Fig.10

A.ARM BED AND ITS ACCESSORIES



A.ARM BED AND ITS ACCESSORIES

Fig. No.	Part No.	Description	Pcs.	Remarks
A01	H7208B8001	Arm	1	
A02	H0308B8001	Bed	1	
A03	H7215B8001	Oil pipe	1	
A04	H7216B8001	Oil wick	3	
A05	HA307B0674	Rubber plug	2	
A06	H7217B8001	Needle bar guide bracket stud bushing	1	
A07	HA100C2020	Set Screw	1	SM15/64(28)×10
A08	HA100C2020	Set Screw	1	SM15/64(28)×10
A09	H7218B8001	Presser bar bushing	1	
A10	HA305E0662	Set Screw	1	SM15/64(28)×4.5
A11	H7219B8001	Pin	1	
A12	HA100C2020	Set Screw	1	SM15/64(28)×10
A13	H7220B8001	Mandril of needle bar guide bracket	1	
A14	H2405D0664	Set Screw	1	SM15/64(28)×14
A15	H7225B8001	Arm side cover	1	
A16	HA100B2060	Screw	1	SM11/64(40)×9
A17	H7236B8001	Face plate	1	
A18	H7238B8001	Screw	2	SM15/64(28)×22
A19	H7240B8001	Thread guide	1	
A20	H3410C301K	Screw	1	SM9/64(40)×6.5
A21	HA115B0702	Nut	1	
A22	H7241B8001	Tension spring	1	
A23	HA310B0705	Tension disc	2	
A24	H7242B8001	Tension screw stud	1	
A25	H2010J0066	Tension nut	1	SM9/32(28)
A26	H7243B8001	Thread tension regulator complete base	1	
A27	HA111G0683	Screw	2	SM11/64(40)×12
A28	H7244B8001	Tension releasing disc	1	
A29	H7245B8001	Screw	1	
A30	H7246B8001	Thread guide	1	
A31	HA115B0702	Tension nut	1	
A32	H7241B8001	Tension spring	1	
A33	H7248B8001	Washer	2	
A34	H7249B8001	Felt	2	
A35	H7250B8001	Damping plate	1	
A36	H7251B8001	Tension screw stud	1	
A37	HA710N0683	Nut	1	SM15/64(28)
A38	H7254B8001	Thread take-up spring	1	
A39	H7253B8001	Spring	1	
A40	H7255B8001	Thread take-up spring guide plate	1	
A41	H3410C301K	Screw	1	SM9/64(40)×6.5
A42	H7257B8001	Screw	1	
A43	H7258B8001	Nut	1	SM1/8(44)

A.ARM BED AND ITS ACCESSORIES

Fig. No.	Part No.	Description	Pcs.	Remarks
A44	H7259B8001	Tension spring	1	
A45	H7260B8001	Tension disc	1	
A46	H7261B8001	Thread tension regulator complete base	1	
A47	HA7311CC06	Screw	1	SM9/64(40)×6
A48	H7262B8001	Thread guide	1	
A49	H3410C301K	Screw	1	SM9/64(40)×6.5
A50	HA300B2100	Rubber plug	1	

B.NEEDLE BAR AND THREAD TAKE-UP MECHANISM

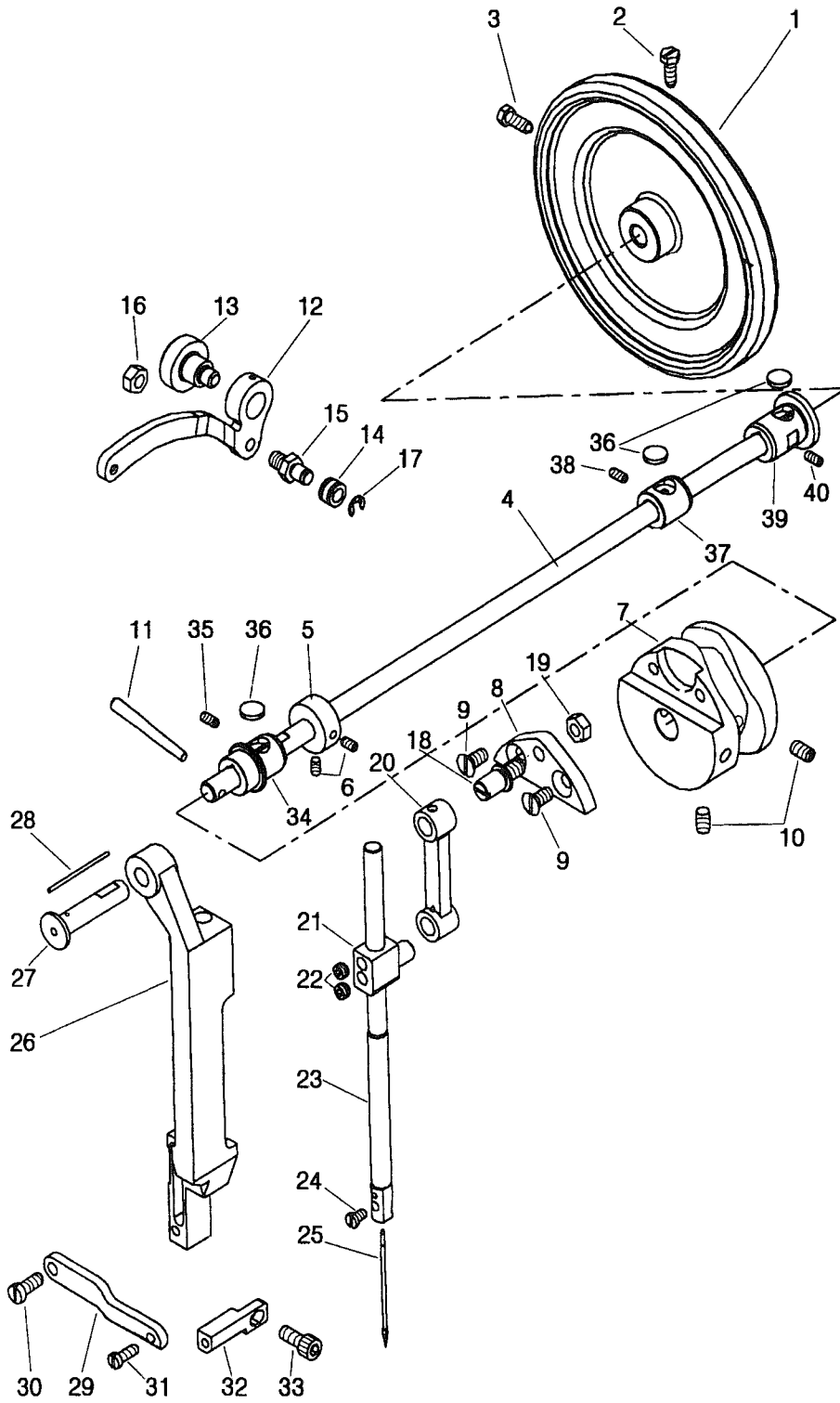

B.NEEDLE BAR AND THREAD TAKE-UP MECHANISM

Fig. No.	Part No.	Description	Pcs.	Remarks
B01	H7204C8001	Pulley	1	放附件箱中
B02	H7205C8001	Screw	1	放附件箱中
B03	H7206C8001	Screw	1	放附件箱中
B04	H7208C8001	Arm shaft	1	
B05	HA108G0661	Collar	1	
B06	HA105D0662	Set Screw	2	SM1/4(40)×6
B07	H7209C8001	Thread take-up cam	1	
B08	H7210C8001	Needle bar connecting base link screw	1	
B09	H403060120	Screw	2	GB/T68 M6×12
B10	H4933K8001	Set Screw	2	SM1/4(40)×10
B11	H602040450	Pin	1	GB/T117 4×45
B12	H7211C8001	Thread take-up lever	1	
B13	H7212C8001	Screw	1	
B14	H7213C8001	Roller	1	
B15	H7214C8001	Roller pin	1	
B16	H2010J0066	Nut	1	SM9/32(28)
B17	H007013050	Retaining ring-E type	1	GB/T896 5
B18	H7215C8001	Needle bar connecting link screw	1	
B19	H2010J0066	Nut	1	SM9/32(28)
B20	H7216C8001	Needle bar connecting link	1	
B21	H7217C8001	Needle bar connecting stud	1	
B22	H7218C8001	Set Screw	2	SM1/4(40)×4.5
B23	H7219C8001	Needle bar	1	
B24	HA700F2100	Screw	1	SM11/64(40)×7
B25	H7220C8001	Needle	1	DY*3 26#
B26	H7222C8001	Needle bar guide bracket	1	
B27	H7223C8001	Needle bar guide bracket pin	1	
B28	H7224C8001	Oil wick	1	
B29	H7225C8001	Needle bar guide bracket plate	1	
B30	H3208G0676	Screw	1	SM15/64(28)×10.5
B31	HA111G0683	Screw	1	SM11/64(40)×12
B32	H7226C8001	Needle bar guide bracket plate base	1	
B33	H415060140	Screw	1	GB/T70.1 M6×14
B34	H7213B8001	Bushing	1	
B35	H2405D0664	Set Screw	1	SM15/64(28)×14
B36	H7214B8001	Felt	3	
B37	H7212B8001	Bushing	1	
B38	H2405D0664	Set Screw	1	SM15/64(28)×14
B39	H7211B8001	Bushing	1	
B40	H2405D0664	Set Screw	1	SM15/64(28)×14

C.LOWER SHAFT MECHANISM

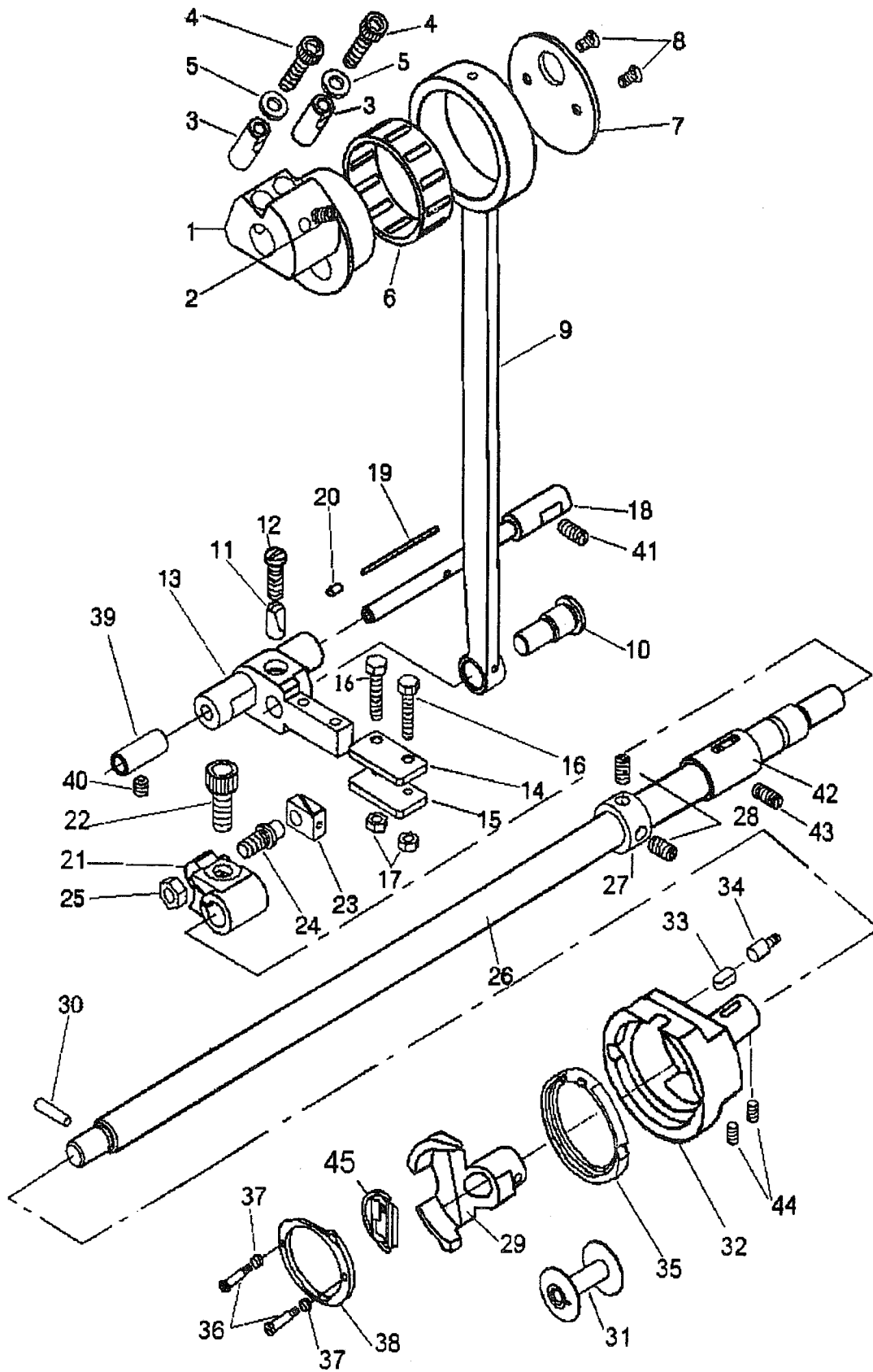

C.LOWER SHAFT MECHANISM

Fig. No.	Part No.	Description	Pcs.	Remarks
C01	H7204D8001	Eccentric	1	
C02	H7205D8001	Set screw	1	SM15/64(28)×12
C03	H7206D8001	Pin	2	
C04	H415060250	Screw	2	GB/T70.1 M6×25
C05	H4728H8001	Washer	2	
C06	H7237D8001	Bearing	1	K43×48×17(NTN)
C07	H7207D8001	Eccentric cover	1	
C08	H2000B2050	Screw	2	SM11/64(40)×9
C09	H7208D8001	Crank connecting rod	1	
C10	H7209D8001	Crank connecting rod pin	1	
C11	H7210D8001	Pin	1	
C12	H7211D8001	Screw	1	SM3/16(32)×18
C13	H7213D8001	Shuttle shaft	1	
C14	H7214D8001	Plate	1	
C15	H7215D8001	Plate	1	
C16	H7216D8001	Screw	2	
C17	H2000M0120	Nut	2	SM11/64(40)
C18	H7218D8001	Inside shaft	1	
C19	H7219D8001	Oil wick	1	
C20	H7220D8001	Rivet	1	
C21	H7222D8001	Lower shaft crank	1	
C22	H415080200	Screw	1	GB/T70.1 M8×20
C23	H7223D8001	Shuttle shaft slide block	1	
C24	H7224D8001	Screw	1	
C25	H2010J0066	Nut	1	SM9/32(28)
C26	H0305D8001	Lower shaft	1	
C27	HA108G0661	Collar	1	
C28	H7239D8001	Set screw	2	SM1/4(40)×3.5
C29	H0306D8001	Shuttle driver	1	
C30	H602040220	Pin	1	GB/T117 4×22
C31	H7228D8001	Bobbin	1	
C32	H0307D8001	Shuttle hook base	1	
C33	H0308D8001	Felt	1	
C34	H0309D8001	Screw	1	SM15/64(28)
C35	H0310D8001	Shuttle race body	1	
C36	H7231D8001	Screw	2	SM3/16(28)
C37	H7232D8001	Spring	2	
C38	H0311D8001	Shuttle race cap	1	
C39	H7234B8001	Bushing	1	
C40	HA100C2020	Set screw	1	SM15/64(28)×10
C41	HA3411D308	Set screw	1	SM15/64(28)×7
C42	H7229B8001	Bushing	1	
C43	HA100C2020	Set screw	1	SM15/64(28)×10

C.LOWER SHAFT MECHANISM

Fig. No.	Part No.	Description	Pcs.	Remarks
C44	H2405D0664	Set screw	2	SM15/64(28) × 14
C45	H7240D7101	Shuttle hook	1	KSP-204N(佐文)

D.FEEDING MECHANISM

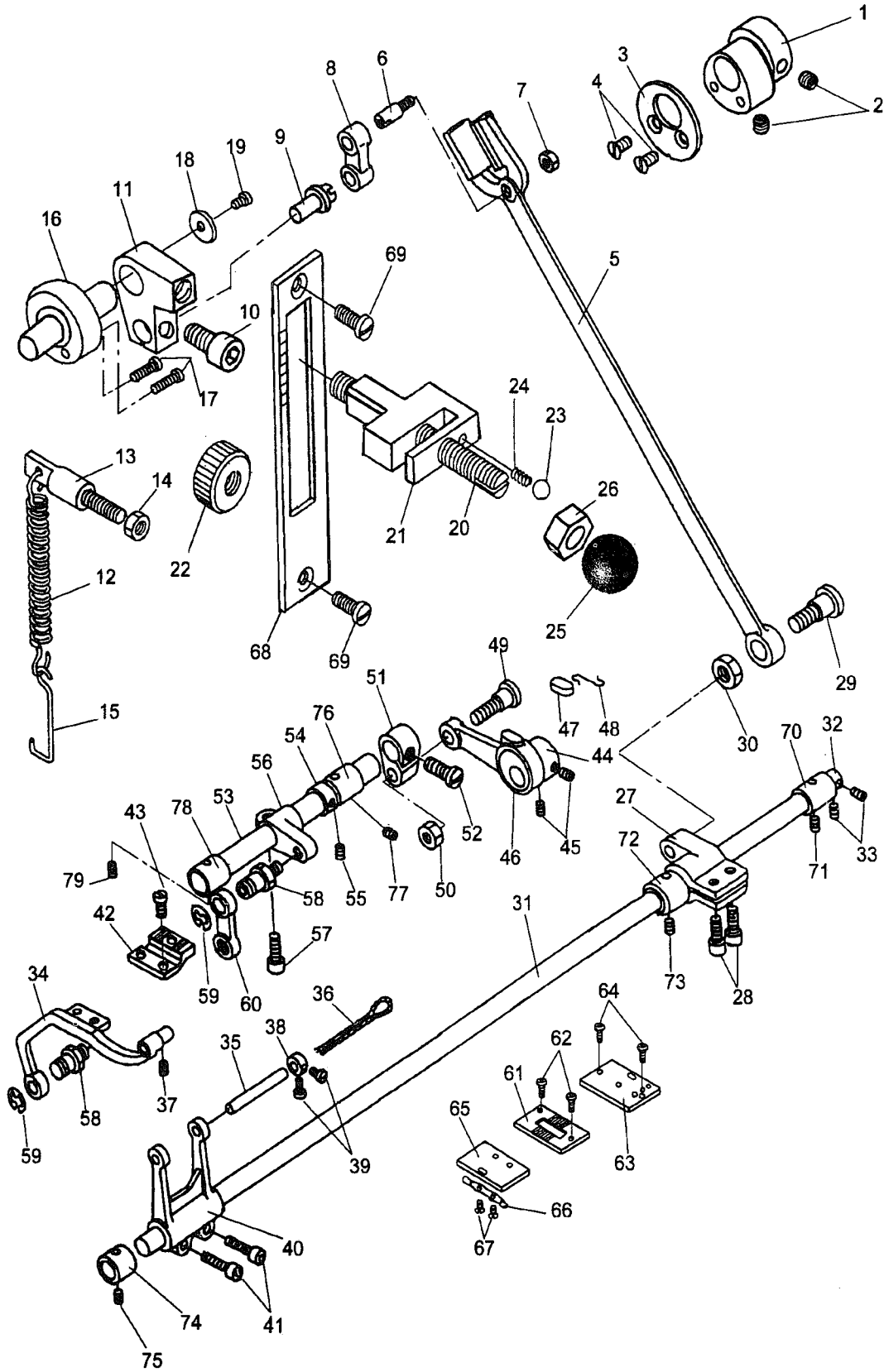

D.FEEDING MECHANISM

Fig. No.	Part No.	Description	Pcs.	Remarks
D01	H0334E8001	Feed cam	1	
D02	H7206E8001	Set screw	2	SM15/64(28)×6
D03	H7207E8001	Feed cam cover	1	
D04	H2000B2050	Screw	2	SM11/64(40)×9
D05	H0304E8001	Feed forked connection	1	
D06	H7209E8001	Feed forked connection crank pin	1	
D07	H2010J0066	Nut	1	SM9/32(28)
D08	H7210E8001	Stitch length connecting link	1	
D09	H7211E8001	Stitch length connecting link crank pin	1	
D10	H415050140	Screw	1	GB/T70.1 M5×14
D11	H0335E8001	Stitch length adjusting pin	1	
D12	H0305E8001	Spring	1	
D13	H0306E8001	Screw bar	1	SM9/32(28)
D14	H2010J0066	Nut	1	SM9/32(28)
D15	H0307E8001	Hook	1	
D16	H0336E8001	Damping plate	1	
D17	HA104G0012	Screw	2	SM3/16(28)×12
D18	H0337E8001	Spacer	1	
D19	H5715B8001	Screw	1	SM11/64(40)×8
D20	H7214E8001	Stitch length adjusting bolt	1	
D21	H7215E8001	Stitch length limited plate	1	
D22	H7216E8001	Nut	1	
D23	HE00001032	Metal ball	1	GB/T308 3.175
D24	H7217E8001	Spring	1	
D25	HF01080320	Plastic ball	1	JB/T7271.1 M8×32
D26	H003008080	Nut	1	GB/T6172.1 M8
D27	H0308E8001	Feed driving rock shaft crank	1	
D28	H415060140	Screw	2	GB/T70.1 M6×14
D29	H0309E8001	Screw	1	
D30	H2010J0066	Nut	1	SM9/32(28)
D31	H0310E8001	Collar	1	
D32	HA108G0661	Set screw	1	
D33	H7239D8001	Crank pin	2	SM1/4(40)×3.5
D34	H0312E8001	Feed dog base	1	
D35	H0313E8001	Crank shaft	1	
D36	H0314E8001	Oil wick	1	
D37	H2100I2070	Screw	1	SM3/16(32)×7
D38	H0315E8001	Collar	1	
D39	H7214H8001	Screw	2	SM11/64(40)×4.5
D40	H0316E8001	Crank	1	
D41	H415060140	Screw	2	GB/T70.1 M6×14
D42	H0317E8001	Feed dog	1	
D43	HA7311CC06	Screw	2	SM9/64(40)×6

D.FEEDING MECHANISM

Fig. No.	Part No.	Description	Pcs.	Remarks
D44	H0318E8001	Feed lifting eccentric	1	
D45	HA307C0066	Screw	2	SM1/4 (40) × 6
D46	H0320E8001	Feed lifting connection	1	
D47	H0321E8001	Felt	1	
D48	H20111C106	Spring	1	
D49	H0323E8001	Screw	1	
D50	H2010J0066	Nut	1	SM9/32×28
D51	H0324E8001	Crank	1	
D52	H6017F8001	Screw	1	SM15/64(28)×18
D53	H0325E8001	Feed lifting shaft	1	
D54	HA108G0661	Collar	1	
D55	H7239D8001	Screw	2	SM1/4(40)×3.5
D56	H0326E8001	Crank	1	
D57	H415060140	Screw	1	GB/T70.1 M6×14
D58	H7219E8001	Hinge bar	2	
D59	H007013080	Washer	2	GB/T896 8
D60	H0327E8001	Link	1	
D61	H0328E8001	Needle plate	1	
D62	HA300B2190	Screw	2	SM11/64(40)×8
D63	H0329E8001	Fitting plate	1	
D64	HA100B2200	Screw	2	SM11/64(40)×8
D65	H0330E8001	Slide plate	1	
D66	H0331E8001	Spring	1	
D67	HA124B0713	Screw	2	SM3/32(56)×2.2
D68	H0332E8001	Stitch length indicating plate	1	
D69	HA104F0654	Screw	2	SM15/64(28)×9
D70	H0311B8001	Bushing	1	
D71	H2405D0664	Set screw	1	SM15/64(28)×14
D72	H0312B8001	Bushing	1	
D73	HA100C2020	Set screw	1	SM15/64(28)×10
D74	H2009B0069	Bushing	1	
D75	H2405D0664	Set screw	1	SM15/64(28)×14
D76	H0312B8001	Bushing	1	
D77	HA3411D308	Set screw	1	SM15/64(28)×7
D78	H0311B800i	Bushing	1	
D79	H2405D0664	Set screw	1	SM15/64(28)×14

E.PRESSER FOOT MECHANISM

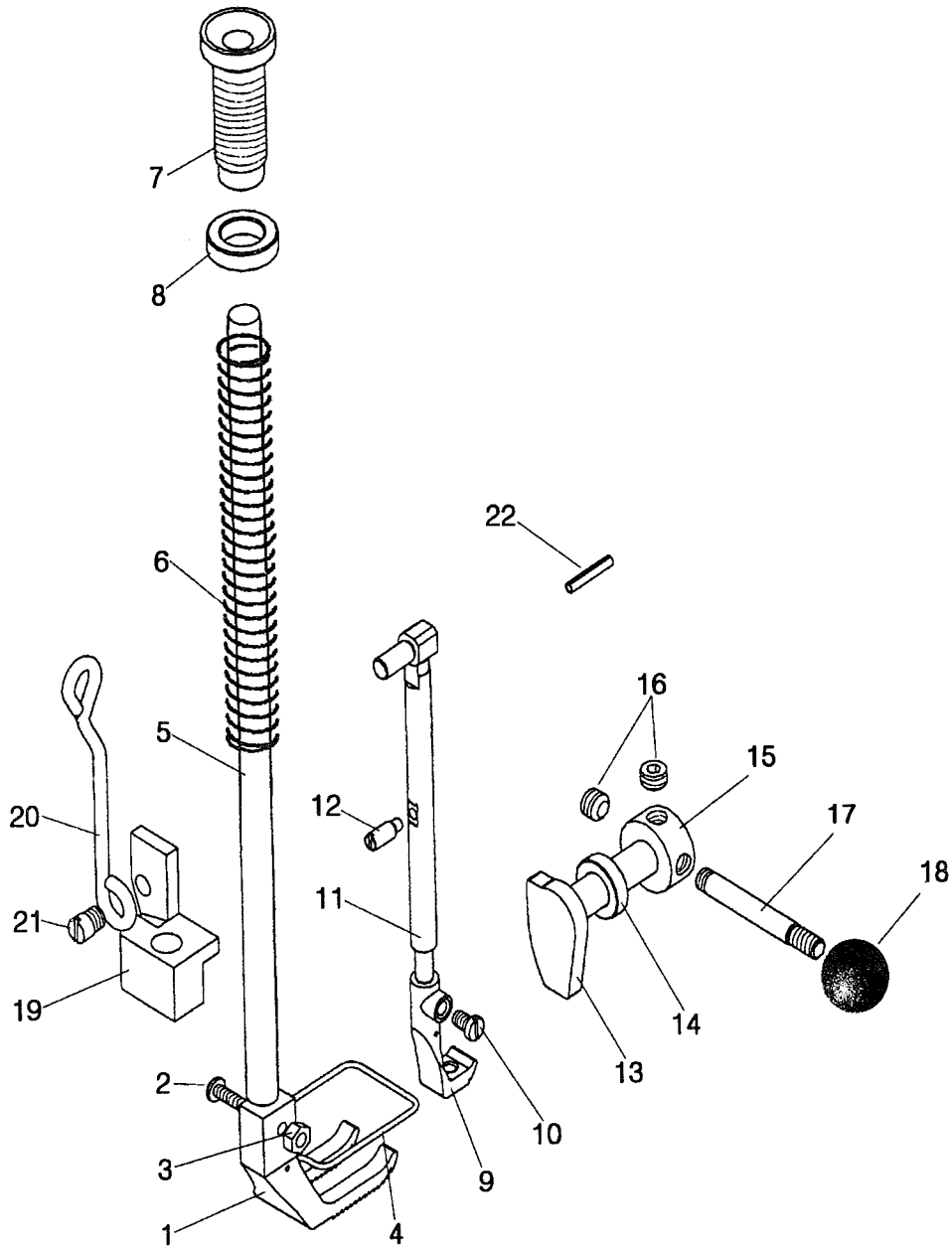

E.PRESSER FOOT MECHANISM

Fig. No.	Part No.	Description	Pcs.	Remarks
E01	H7204F8001	Presser foot	1	
E02	H7205F8001	Screw	1	SM9/64 (40) × 14
E03	HA710P0673	Nut	1	SM9/64 (40)
E04	H7206F8001	Finger guard	1	
E05	H7207F8001	Presser bar	1	
E06	H7208F8001	Presser bar spring	1	
E07	H7209F8001	Thumb screw	1	SM5/8(28)
E08	H7210F8001	Nut	1	
E09	H7211F8001	Walking foot	1	
E10	HA719B0709	Screw	1	SM11/64(40)×7
E11	H7212F8001	Presser bar	1	
E12	H7213F8001	Screw	1	
E13	H7214F8001	Presser bar lifting shaft	1	
E14	H7215F8001	Washer	1	
E15	H7217F8001	Collar	1	
E16	H7218C8001	Set screw	2	SM1/4(40)×4.5
E17	H7219F8001	Bolt	1	
E18	HF01080320	Plastic ball	1	JB/T7271.1 M6×20
E19	H7220F8001	Presser bar guide bracket	1	
E20	H7221F8001	Connecting rod	1	
E21	H7222F8001	Screw	1	SM1/4(40)×40
E22	H609030180	Pin	1	GB/T879.1 3×18

F.UPPER FEED LIFTING ROCK SHAFT MECHANISM

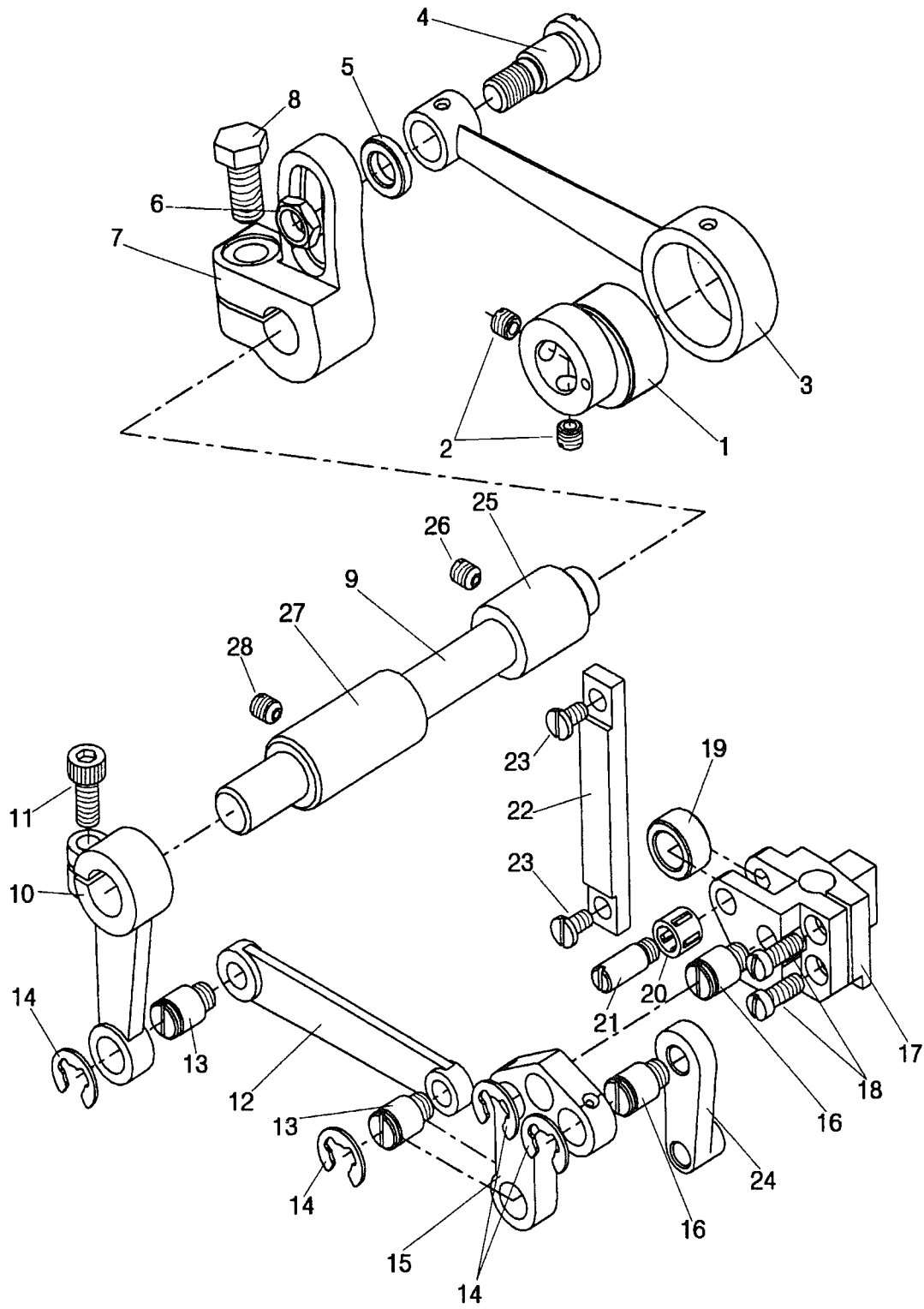

F.UPPER FEED LIFTING ROCK SHAFT MECHANISM

Fig. No.	Part No.	Description	Pcs.	Remarks
F01	H7204G8001	Presser foot lifting eccentric	1	
F02	HA307C0066	Set screw	2	SM1/4 (40) × 6
F03	H7205G8001	Eccentric connecting link	1	
F04	H7206G8001	Screw	1	
F05	H7207G8001	Washer	1	
F06	H7208G8001	Nut	1	SM11/32(28)
F07	H7209G8001	Adjusting crank	1	
F08	H7210G8001	Screw	1	SM5/16(18)
F09	H7211G8001	Presser foot lifting shaft	1	
F10	H7212G8001	Presser foot lifting shaft crank	1	
F11	H415060140	Screw	1	GB/T70.1 M6×14
F12	H7213G8001	Presser foot lifting connecting link	1	
F13	H7214G8001	Screw	2	
F14	H007013080	Retaining ring-E type	4	GB/T896 8
F15	H7215G8001	Presser foot lifting lever	1	
F16	H7214G8001	Screw	2	
F17	H7216G8001	Presser foot lifting lever base	1	
F18	HA104G0012	Screw	2	SM3/16(28)×12
F19	H7217G8001	Roller	1	
F20	H7221G8001	Bearing	1	ISO K7
F21	H7218G8001	Screw	1	SM15/64(28)
F22	H7219G8001	Roller base plate	1	
F23	HA700B2060	Screw	2	SM3/16(32)×8
F24	H7220G8001	Walking foot lifting connecting link	1	
F25	H7221B8001	Bushing	1	
F26	HA3411D308	Set screw	1	SM15/64(28)×7
F27	H7222B8001	Bushing	1	
F28	HA3411D308	Set screw	1	SM15/64(28)×7

G.NEEDLE BAR ROCKING MOTION MECHANISM

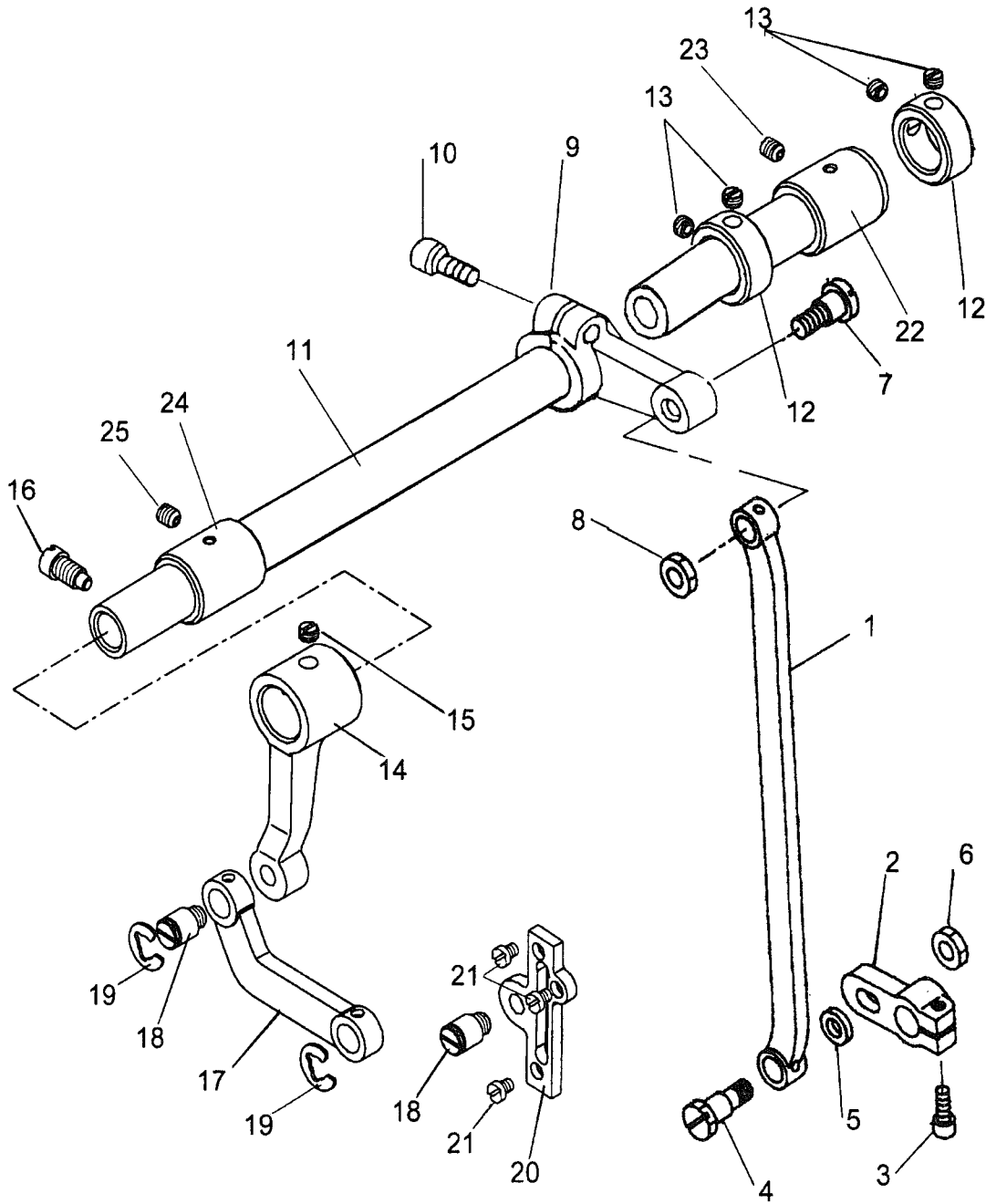

G.NEEDLE BAR ROCKING MOTION MECHANISM

Fig. No.	Part No.	Description	Pcs.	Remarks
G01	H0304H8001	Needle bar rocking connecting link	1	
G02	H0305H8001	Adjusting crank	1	
G03	H415060140	Screw	1	GB/T70.1 M6×14
G04	H7206G8001	Screw	1	
G05	H7207G8001	Washer	1	
G06	H7208G8001	Nut	1	
G07	H0309E8001	Screw	1	
G08	H2010J0066	Nut	1	SM9/32(28)
G09	H0306H8001	Adjusting crank	1	
G10	H415060160	Screw	1	GB/T70.1 M6×16
G11	H7209H8001	Needle bar rock shaft	1	
G12	H7210H8001	Collar	2	
G13	HA105D0662	Set screw	4	SM1/4(40)×4.5
G14	H7211H8001	Needle bar rocking crank	1	
G15	H7218C8001	Set screw	1	SM1/4(40)×4.5
G16	HA100C2070	Screw	1	SM9/32(28)×14
G17	H7212H8001	Needle bar rocking connecting link	1	
G18	H7214G8001	Screw	2	
G19	H007013080	Retaining ring-E type	2	GB/T896 8
G20	H7213H8001	Screw base	1	
G21	H7214H8001	Screw	3	SM11/64(40)×4.5
G22	H7223B8001	Bushing	1	
G23	HA3411D308	Set screw	1	SM15/64(28)×7
G24	H7224B8001	Bushing	1	
G25	HA3411D308	Set screw	1	SM15/64(28)×7

H.KNEE LIFTER MECHANISM

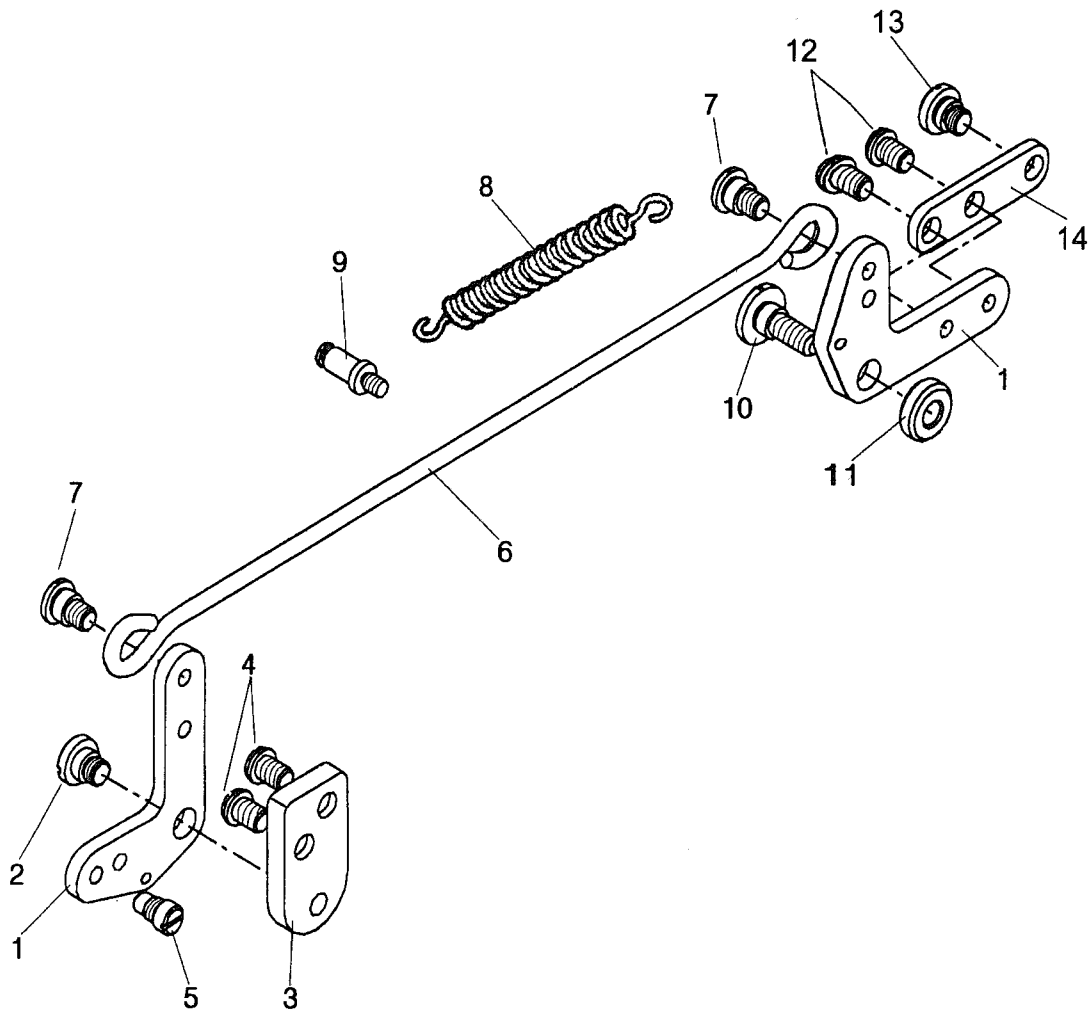

J.ACCESSORIES

Fig. No.	Part No.	Description	Pcs.	Remarks
J01	H7207K8001	Silicon oil box	1	
J02	H7208K8001	Cover	1	
J03	H605030400	Pin	1	GB/T119.2 3×40
J04	H34411C410	Screw	1	SM9/64(40)×4
J05	H7209K8001	Spring	1	
J06	H3215K0693	Screw	1	SM9/64(40)5
J07	H7210K8001	Thread guide	2	
J08	H7211K8001	Nut	2	SM3/32(56)
J09	HA800F2020	Screw	1	SM15/64(28)×13.5
J10	HB00001050	Hexagon socket screw key	1	GB/T5356 5
J11	HB00001040	Hexagon socket screw key	1	GB/T5356 4
J12	HB00001030	Hexagon socket screw key	1	GB/T5356 3
J13	HA300J2070	Screw driver (size L)	1	
J14	HA300J2200	Scrwe driver (size M)	1	
J15	HA300J2210	Scrwe driver (size S)	1	
J16	HJ02090110	Spanner	1	GB/T4388 9×11
J17	HJ02100130	Spanner	1	GB/T4388 10×13
J18	H7228D8001	Bobbin	4	
J19	H7220C8001	Needle	4	DY*3 26#
J20	H7235K8001	Hook	1	
J21	HPG100E202	Hook	1	
J22		Chain	1	1100mm
J23	HA200J2030	Thread stand assy	1	
J24	H2004O0069	Oiler	1	聚丙烯
J25	H7212K8001	Vinyl cover	1	聚氯乙烯
J26	H0306K8001	Oil pan	1	
J27	16250	Nail	6	GB349 1.6×25
J28	H0307K8001	Supporting bar	1	
J29	HE009M8001	Hinge	2	
J30	HE010M8001	Screw	4	
J31	HE007M8001	Hinge socket	2	
J32	16250	Nail	4	GB349 1.6×25
J33	HE005M8001	Cushion	4	
J34	16250	Nail	4	GB349 1.6×25

SHANGHAI HUIGONG NO.3 SEWING MACHINE FACTORY

ADD: 1418, Yishan Road, Shanghai, China

Zip Code: 201103

Overseas Business: TEL: 86-21-64853303 FAX: 86-21-64854304

E-mail: highlead@online.sh.cn <http://www.highlead.com.cn>

The description covered in this manual is subject to change for improvement of the commodity without notice

2004.2. Printed